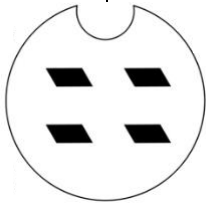
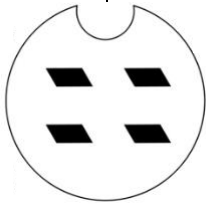
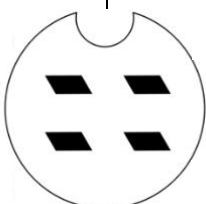
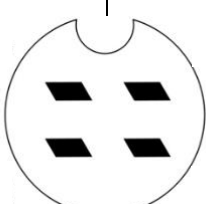
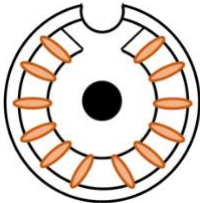
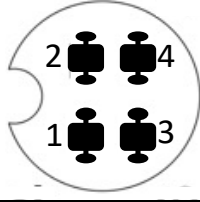

User/Lab:	Session Date:	Project ID:
Pixel Size:	BSL 2? No <input type="checkbox"/> Yes <input type="checkbox"/> → If Yes, disposal method:	
Tube name: (YOUR NAME)	Special Requests:	Krios1 <input type="checkbox"/> Krios2 <input type="checkbox"/> Talos <input type="checkbox"/> Aquilos <input type="checkbox"/>

Grid Box Name:	
Grid Box Name:	
Grid Box Name:	
Grid Box Name:	

FOR STAFF USE ONLY

Puck & Slot:				Car	Grid	O/X*
Auto Grid Box Name:				12		
				11		
Grid Box Position				10		
1		7		9		
2		8		8		
3		9		7		
4		10		6		
5		11		5		
6		12		4		
Grids saved after session				3		
				2		
Grid box name:		Grid box name:		1		
Position	Car	Position	Car			
1		1				
2		2				
3		3				
4		4				
Grid box name:		Grid box name:				
Position	Car	Position	Car			
1		1				
2		2				
3		3				
4		4				
				Rings		
				C-clips		
				Boxes		
				Training		
				Session		
				Duration		

- Extra grids back in tube N/A
 Grids from TEM back in tube N/A

* O: keep X: toss

PICK UP YOUR GRIDS BY:
(7 days after data collection)